

# Kwikdraw-A 17KM/HDM

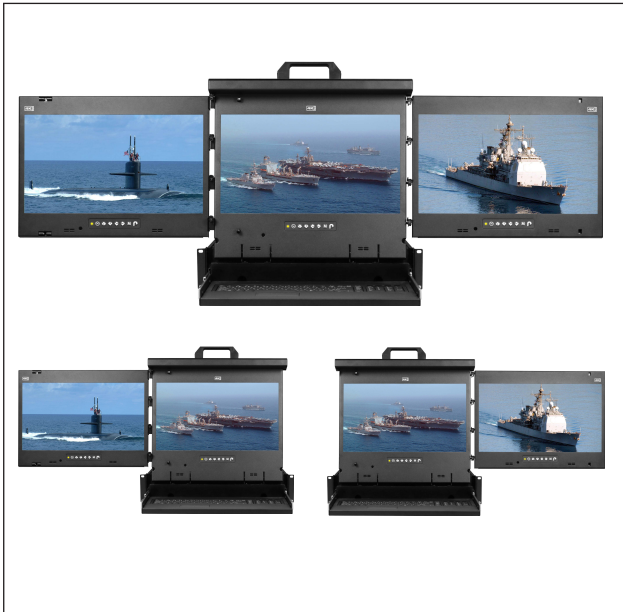

## Features

Key features:-

- 2U 22" short depth design
- Light weight: only 49 lbs / 22 kgs
- Rugged construction for mobility & durability
- Built-in solid bearing slide rails
- Built-in dual stereo speaker ( per display )
- 104-key keyboard with touchpad
- 2-year standard warranty

## Dimensions

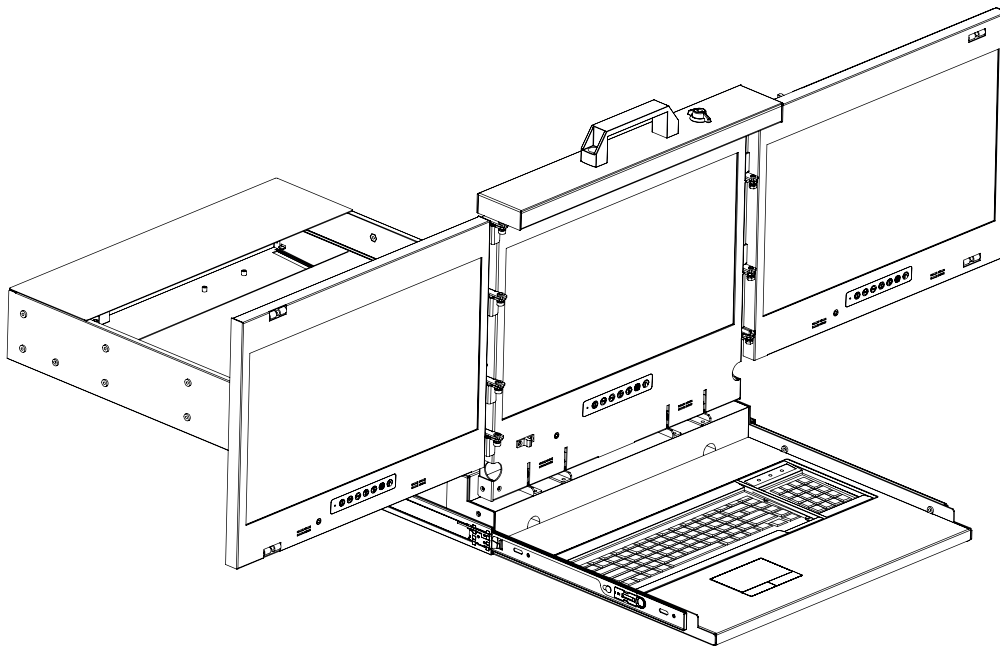

### 4K 17" Display

3840 x 2160 native resolution / Display port 1.2 video input  
1920 x 1080 & 1920 x 1200 resolution support

17KM - 3	Triple display console drawer
17KM - 2L	Dual display console drawer (LH mounted)
17KM - 2R	Dual display console drawer (RH mounted)

### FHD 17" Display

1920 x 1080 native resolution / DVI-D + VGA video input

17KM - 3	Triple display console drawer
17KM - 2L	Dual display console drawer (LH mounted)
17KM - 2R	Dual display console drawer (RH mounted)

Sales: +44 (0) 1273 570 220 Admin: +44 (0) 1273 608 331 Fax: +44 (0) 1273 570 215 Website: [www.amplicon.com](http://www.amplicon.com) Email: [sales@amplicon.com](mailto:sales@amplicon.com)

## Kwikdraw-A 17KM/HDM

### Specifications

The information is believed to be accurate. However Amplicon Liveline Limited accepts no responsibility for any problems caused by errors and omissions. Specifications are subject to change without notice.

LCD Panel		Kwikdraw-A 17KM	Kwikdraw-A 17HDM	Physical			
Native resolution		3840 x 2160	1920 x 1080	Product	mm	441.6 x 550 x 88	
Panel size (diagonal)		17.3"	17.3"		inch	17.4 x 21.7 x 3.5	
Brightness (cd/m <sup>2</sup> )		400	400	Packing	mm	585 x 620 x 190	
Contrast ratio (typ.)		1000 : 1	600 : 1		inch	23 x 24.4 x 7.5	
Colors		16.7 M, 8-bit	16.7 M, 8-bit	Weight	Net	Triple display	25.4 kg / 55.9 lb
Viewing angle (L/R/U/D)		89/89/89/89	80/80/60/80			Dual display	23.4 kg / 51.5 lb
Response time (ms)		Max. 30	40	Gross	Triple display	30.4 kg / 66.9 lb	
Dot pitch (mm)		0.0995	0.1989			Dual display	28.4 kg / 62.5 lb
Display area (mm)		382.12H x 214.94V	381.888H x 214.812V	Chassis color		Dark	
Surface treatment		Anti-glare	Anti-glare, Hard-coating	Chassis materials		Steel	
Surface hardness		3H	3H	<b>Compliance</b>			
Backlight type		LED	LED	Safety		CE certified	
MTBF (hrs)		20,000	50,000	Environment		RoHS2 & REACH compliant	
Video		Kwikdraw-A 17KM	Kwikdraw-A 17HDM	Environment			
Digital	Display port	DP 1.2 / HDCP 1.3	-	Operating temp.	0 to 55°C degree		
	HDMI	HDMI 1.4 / HDCP 1.4 HDMI 2.0 / HDCP 2.2	HDMI 1.3 / HDCP 1.3	Storage temp.	-20 to 60°C degree		
	DVI-D	-	DVI-D, TMDS single link	Operating humidity	20~90%, non-condensing		
Analog	VGA	-	Analog 0.7Vp-p	Storage humidity	5 ~90%, non-condensing		
Plug & Play	DVI / VGA	-	VESA EDID structure 1.3	Operating altitude	16,000 ft		
Synchronization	VGA	-	Separate, Composite & SOG	Non-operating altitude	40,000 ft		
Power		Kwikdraw-A 17KM	Kwikdraw-A 17HDM	Shock	10G acceleration ( 11ms duration )		
Input		Auto-sensing 100 to 240VAC, 50 / 60Hz		Vibration	10~300Hz 0.5G RMS random vibration		
Consumption	Screen on	Max. 29W	Max. 25W				
	Power Saving	Max. 9W	Max. 4W				
	Power Button on	Max. 2W	Max. 1W				

Front View

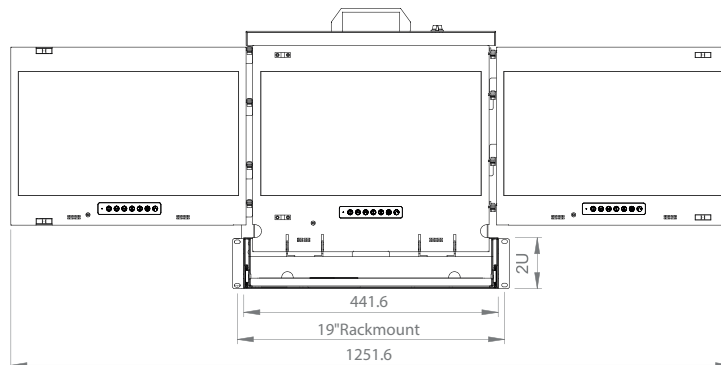

Side View

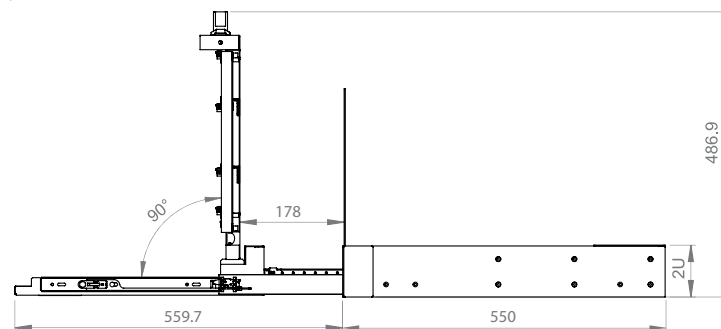

Sales: +44 (0) 1273 570 220 Admin: +44 (0) 1273 608 331 Fax: +44 (0) 1273 570 215 Website: [www.amplicon.com](http://www.amplicon.com) Email: [sales@amplicon.com](mailto:sales@amplicon.com)